

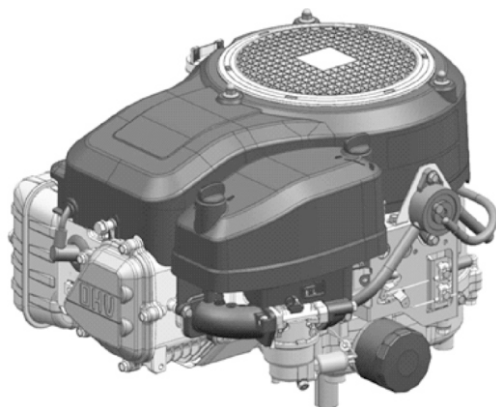

# XP600 Series Gasoline Engines

## OPERATOR'S MANUAL



Read this manual carefully before operation.  
This manual includes important guidance for safety operation.



## Table of Contents

Attention.....	1
Chapter 1 General .....	2
Chapter 2 Structural Illustrations and Working Principle of Gasoline Engine .....	4
Chapter 3 Safety Precautions.....	6
Chapter 4 Technical Characteristics.....	9
Chapter 5 Operation .....	11
Chapter 6 Common Faults .....	16
Chapter 7 Maintenance .....	18
Chapter 8 Transportation and Storage .....	20
Chapter 9 Unpacking .....	20
Chapter 10 Warranty Description .....	21
Chapter 11 Installation Dimension.....	22



## Attention

Please read this Manual carefully before using the gasoline engine.

The Company reserves the right to modify the manual without prior notice, and does not bear any responsibility therefrom.

It is prohibited strictly to copy or duplicate any information contained in the Manual without our written consent.

Please note very important information in the Manual highlighted by the following symbols.

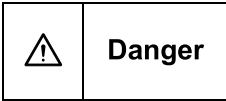

: Indicates a potential hazard that will result in severe personal injury or even death.

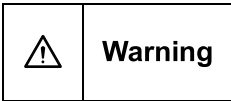

: Indicates a potential hazard that could result in severe personal injury or even death.

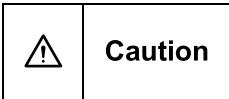

: Indicates a potential hazard that could result in personal injury.



- This Manual is an important integral part of the gasoline engine. When the engine is transferred to others, the Manual shall be attached with the engine. Only one model is illustrated by the figures, which can be used as reference for other models.

## **Chapter 1      General**

Thank you for your purchase of our gasoline engine.

The Manual applies to ZSXP600 series (XP550E-3, XP570E-3, XP600E-3 and XP620E-3) gasoline engines. The engine, XP620E-3, with single cylinder and vertical shaft, currently has the world largest displacement, and can be used as power source for general machinery such as lawn mower, mini-tiller, agricultural machinery, and other universal machinery. It can be normally operated under ambient temperature of 253~313K.

The engine present many advantages as easy and reliable start, large power output, evident fuel efficiency, low noise and emission, various types of power output end, and complete after-sales service network allowing you operate it free from worry.

The engine employs single cylinder, vertical arrangement, overhead valve, forced lubrication, forced air cooling, four strokes and transistorized ignition. They are small in size, light in weight, and compact in structure.

The Manual mainly shows main parts' functions, operation instructions, maintenance, etc. about XP600 series gasoline engines. Please read it carefully and use it correctly to reduce the fault of gasoline engine during operation and to prolong its service life.

The Manual includes the latest and timely operation and maintenance information of XP600 series gasoline engines (Figures in the Manual may differ from the physical gasoline engines and are for reference only), which can guide your operation. As our products are continuously improved and updated, the series gasoline engine is subject to any improvement or modification in future without notice.

The Manual shall be considered as an integral part of the gasoline engine, which shall be attached with the engine when the engine is transferred to others.



**Caution**

- Be sure to read the Manual carefully before using, and operate it in strict accordance with the Manual. Our gasoline engine is safe and reliable; it will not result in injury or equipment damage.
- However, noncompliance with the requirements in the Manual will cause severe injury or equipment damage.

## Chapter 2 Structural Illustrations and Working Principle of Gasoline Engine

1. Structural illustration (See Fig. 1, 2 and 3).

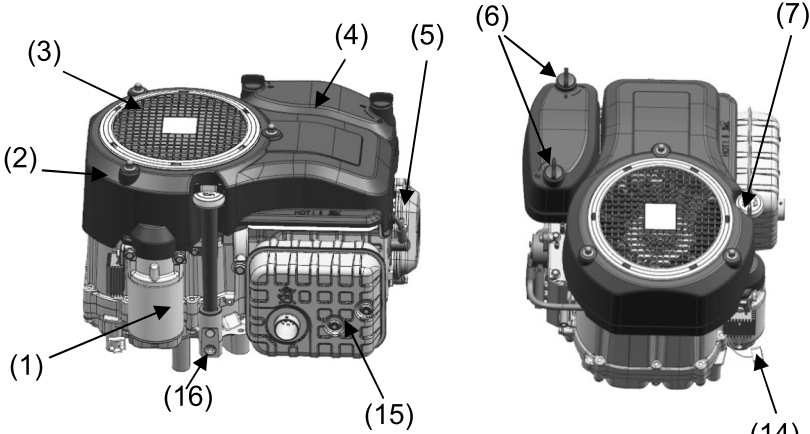

Figure 1

Figure 2

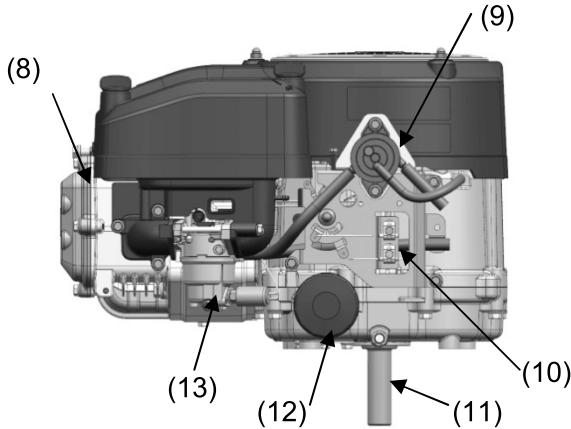

Figure 3

- |                         |                            |                         |                 |
|-------------------------|----------------------------|-------------------------|-----------------|
| (1) Starting motor      | (2) Air director           | (3) Grass cover         | (4) Air cleaner |
| (5) Lifting bolt        | (6) Air cleaner cover knob | (7) Oil ruler           |                 |
| (8) Cylinder head cover | (9) Gasoline pump          | (10) Throttle operating |                 |
| (11) Crankshaft         | (12) Secondary oil filter  | (13) Carburetor         |                 |



- (14) Charger output cable      (15) Exhaust silencer      (16) Oil drain plug

## 2. Working principle

It is a mechanical device in which combustion of fuel in cylinder drives working piston to reciprocate, then chemical energy of the fuel is converted to mechanical energy to output shaft power.

## 3. Model compositions and corresponding meanings (See Fig. 4):

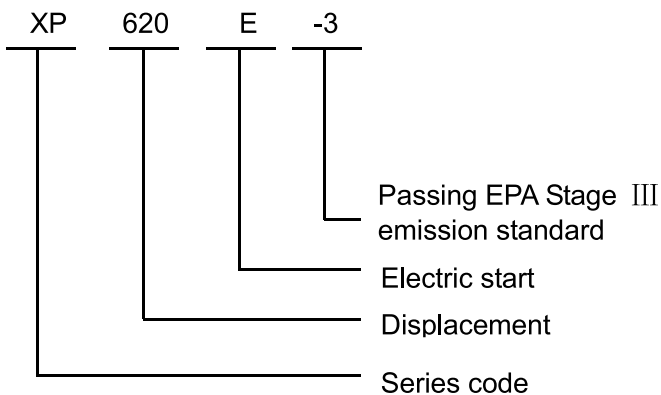

Figure 4

## Chapter 3 Safety Precautions

### 1. To ensure safe operation



- Do not operate the engine if you lose your form or after you drink alcohol; otherwise damage may be caused.

### 2. General safe precautions

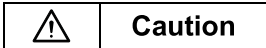

- Gasoline engine must be operated by operator with sufficient professional knowledge. It is forbidden that untrained people operate it independently.
- Keep gasoline out of touch of children.
- It is not allowed to store inflammable, explosive and other dangerous products surrounding the gasoline engine, to avoid fire.
- The working environment shall be well ventilated and there shall be no fire source within range of 10m.
- Shut the engine down in the process of filling fuel and lubricating oil.
- Smoking is strictly prohibited during gasoline filling. Care shall be taken to prevent gasoline from spilling. If it spills, clean away the gasoline stain before starting the engine.
- Do not start the engine in case of no or insufficient lubricating oil filled, to avoid the engine being damaged.
- Pay special attention to the following safety symbol for the sake of your and other's safety.



- Don't touch the muffler for it is quite hot when the gasoline engine is running and just stops running. Place it indoors after it is cooled.
- Exhaust system of the gasoline engine is quite hot when the engine is running and just stops running. To avoid scalding, pay attention to the warning on the gasoline engine.
- The gasoline engine can run safely and reliably according to design requirements if you follow the Manual to operate it. Before operating the engine, please read this Manual carefully and understand it, otherwise, personal injury or equipment damage may be caused.
- Be sure to fill gasoline in a ventilated place for it is inflammable and explosive. Shut the engine down and keep away from smoke and spark before filling gasoline. Please wipe the gasoline immediately in case of spilling.
- As exhaust gas contains carbon monoxide, do not operate the engine indoors. Adequate ventilation must be provided.

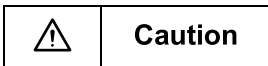

- Exposure to gasoline and lubricating oil repeatedly

or chronically may result in skin cancer. Although it is unlikely to have skin cancer, it is not impossible if you expose gasoline and lubricating oil every day. Therefore, clean your hands with clean water and soap as soon as possible every time after using gasoline and lubricating oil. Keep them out reach of children.



**Caution**

- Do not pollute the environment. For used gasoline and lubricating oil, it is recommended to send them to waste disposal field or waste recovery station after enclosing with a container.
- Do not dump used gasoline and lubricating oil on the ground, or pour them into sewer.
- Keep the gasoline engine in a level position during warm-up to ensure rapidly thoroughly drain out the lubricating oil.

## Chapter 4 Technical Characteristics

### 1. Main Performance Parameters:

Model		XP550	XP570	XP600	XP620
Max. power and corresponding speed, kW/(r/min)		11.5/[3600 ( $\pm 5\%$ )]	11.8/[3600 ( $\pm 5\%$ )]	12.0/[3600 ( $\pm 5\%$ )]	12.2/[3600 ( $\pm 5\%$ )]
Max. torque and corresponding speed, N·m/(r/min)		33.0/[2800 ( $\pm 5\%$ )]	35.0/[2800 ( $\pm 5\%$ )]	36.0/[2800 ( $\pm 5\%$ )]	38.0/[2800 ( $\pm 5\%$ )]
Min. idling stable speed, r/min		1750 $\pm$ 150			
Governing properties	Stable governing ratio, %	$\leq 10$			
	Speed fluctuation ratio, %	$\leq 3$			
	Speed stabilization time, s	-			
Starting properties	Started at ambient temperature of 253K~313K (s)	$\leq 30$			
		$\leq 30$			
	Started after suddenly stopped during normal operation (s)	$\leq 10$			

2. Main Structural Parameters:

Model		XP550	XP570	XP600	XP620
Total displacement, mL		546.8	571.5	596.8	622.5
Cylinder diameter, mm		90	92	94	96
Piston stroke, mm		86	86	86	86
Compression ratio		8.5 : 1	8.0:1	8.5 : 1	8.7:1
Valve clearance mm	Inlet valve	0.08~0.12			
	Exhaust valve	0.08~0.12			
Ignition advance angle, (o)		26° ± 1°			
Lubrication mode		Full forced lubrication			
Starting mode		12V Electric start			
Air cleaner		Foam and paper filter element			
Fuel oil grade		≥Grade 90 (GB 17930-1999)			
Ignition mode		Transistor ignition			
Spark plug clearance, mm		0.60~0.80			
Net mass, kg		31.5			
Lube oil grade		10W/30 SAE			
Fuel oil consumption rate, g/(kW·h)		≤370			
Rotation direction		Counterclockwise (view from crankshaft output end)			
Overall dimensions, L ×W ×H, mm		475×410×(320+80)			

## Chapter 5 Operation

### 1. Preparation and check before operation



- Fill the lubricating oil before operation, because it is unfilled before delivery.

#### 1.1 Check lubricating oil level

- Remove oil ruler and wipe it clean.
- Insert the oil ruler into gasoline engine without turning it and then take out the rule to ascertain the oil level.
- Add lubricating oil to upper limit of oil level if the oil level is low. See Fig. 5.

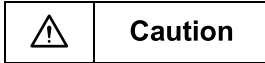

User shall use different grades of lubricating oil according to different environmental temperature.

Recommended lubricating oil: SAE 10W/30.

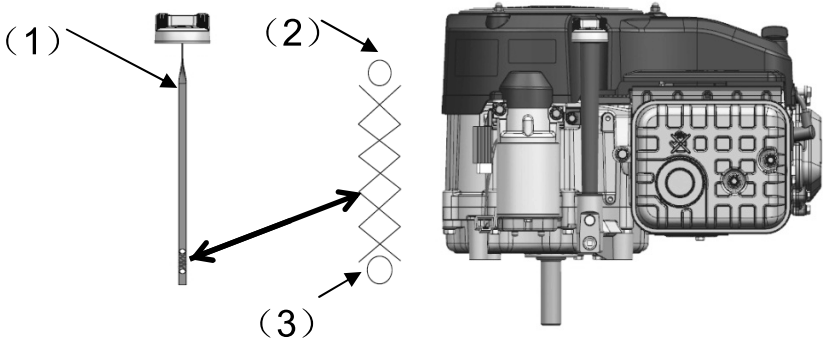
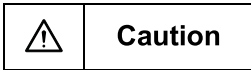

Figure 5

(1) Oil ruler (2) Maximum oil level (3) Minimum oil level

## 1.2 Fuel

Use the gasoline for vehicles. It is better to use lead free or low-lead gasoline, which can reduce the accumulation in combustion chamber. Never use the mixed oil of lubricating oil or gasoline. Avoid dust, trash and water dropping into the fuel tank.



- Gasoline will explode under a certain condition for it is very inflammable.
- Add gasoline in a well ventilated place. Stop gasoline engine running when filling gasoline. Do not smoke at gasoline filling area. No naked fire and spark at gasoline storage area.
- Do not overfill gasoline (there should be no gasoline at the neck of oil filler). Check if fuel tank cover is put on properly.
- Do not spill gasoline during filling. Spilling gasoline or gasoline volatile gas may take fire. In case of gasoline spillage, ensure the spilling gasoline volatilizes off before starting.
- Avoid skin being in touch with gasoline or inhale gasoline volatile gas repeatedly or for a long time. Keep gasoline out of touch of children.

## 1.3 Air cleaner

Check if there is dust or obstacle in the air cleaner. See Figures 6, 7 and 8.

Never run gasoline engine without air cleaner, which will quicken the wear of the engine.



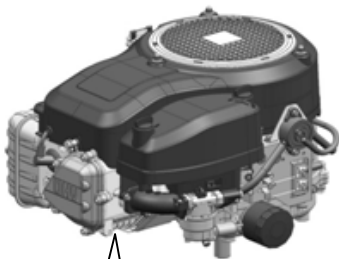

Unscrew the cover knob of air cleaner

Figure 6

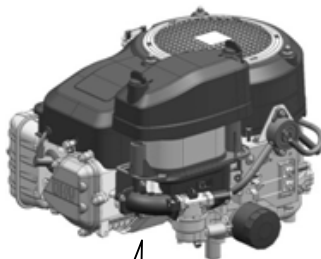

Remove air cleaner cover

Figure 7

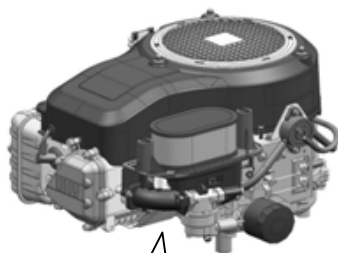

Check air cleaner element for dust or obstacle

Figure 8

2. Start of gasoline engine

- 2.1 The engine is started against 12V DC power supply or 12V accumulator. Connect the positive electrode of the power line to that of the starting motor and its

negative electrode to the terminal, open the throttle to an appropriate degree, and adjust the air damper to the OFF position for starting. After then, reset the air damper. See Figure 9 and 10.

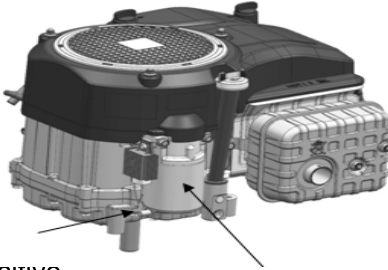

Positive electrode of starting motor

Negative electrode of starting

Figure 9

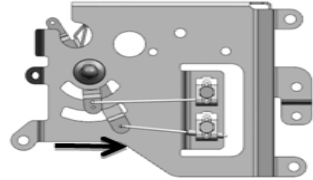

Figure 10

	<b>Caution</b>
--	----------------

The engine only can be started against 12V DC power supply or 12V accumulator.

- 2.2 After the gasoline engine is warmed up, adjust the throttle control system and adjust the gasoline engine speed to FAST (high speed: 3300rpm) or SLOW (low speed: 1750rpm). See Figure 11.

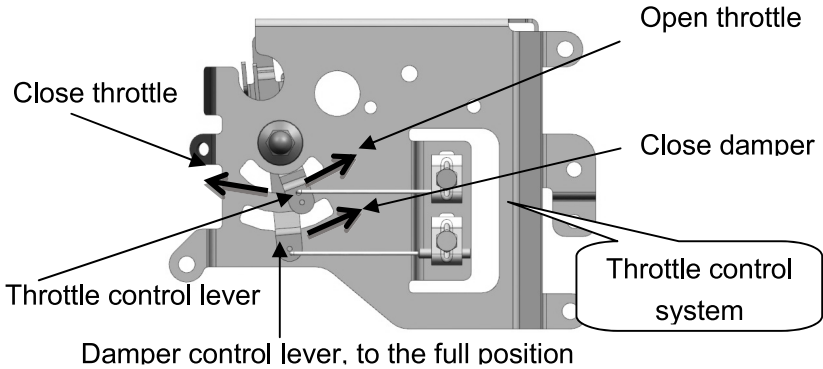

Figure 11

3. Shutdown

Generally, the following steps are taken to shut the engine down.

Adjust throttle lever or throttle cable to low speed position, and then shut the engine down.



- For the sake of your health, please keep away from muffler and do not face the exhaust opening when the gasoline engine is in operation. Pay attention to the abnormal changes to the engine when it is running. In case of any unhealthy symptom such as abnormal sound, severe shock, serious hunting and blasting. Shut down the engine emergently.
- In case of failure to stop it, directly remove the spark plug cap.
- It is not allowed to directly shut the engine down before unloading under normal conditions.

## Chapter 6 Common Faults

### 1. Failure to start or difficulty in start (See Table 2)

Table 2 Failure to Start or Difficulty in Start

Symptom		Cause	Troubleshooting
No spark from ignition plug	Ignition plug	Carbon deposit in ignition plug Excessive or insufficient plug clearance Damaged insulation of ignition plug	Clear off carbon deposit. Adjust the clearance to 0.6~0.8mm Replace ignition plug.
	Others	Failure in igniter Weak magnetic force of flywheel	Replace igniter. Replace flywheel
Spark from ignition plug	Good compression	Too much fuel in cylinder  Unqualified fuel, fuel mixed with water, or dirty fuel	Screw out ignition plug to mop up it, and then screw it in again.  Replace fuel.
	No gasoline bleeding after unscrewing the bleeding bolt at the bottom of carburetor.	Blocked needle valve.	Clean or Replace carburetor
	Normal fuel supply but poor compression	Worn piston ring Loose ignition plug  Leaky cylinder head, improper valve clearance or timing	Replace it. Tighten it.  Eliminate, readjust or reinstall it.
Spark from ignition plug	Normal ignition and fuel supply	Poor contact between high tension wire and ignition plug  Failure or short circuit in shutdown switch.	Clean and connect them.  Eliminate the fault.

2. Abnormal conditions during operation (See Table 3)

Table 3 Abnormal Conditions during Operation

Symptom	Cause	Troubleshooting
Low speed and insufficient power	Unopened choke Unsmooth ventilation of muffler Worn moving element Undesirable balance of speed governing system Low ignition energy Excessive valve clearance Carbon deposit in cylinder head	Open the choke. Replace the muffler. Check and replace the element. Adjust the speed governing system Replace the igniter or flywheel. Replace related component. Clear off carbon deposit.
High speed fluctuation	The governor gear fails to reach optimal balance. Improper carburetor Improper plug clearance	The governor gear fails to reach optimal balance. Replace the carburetor Adjust the clearance.
Too high speed	Speed governing lever does not hold down governing cap tightly or governing cap drops out.	Readjust or install the governing cap.
Abnormal noise	Improper valve clearance Damaged cam teeth	Replace related component. Replace the camshaft.
Leaky carburetor	Needle valve adhered to oily dirt Deformed O ring.	Slightly tap carburetor or clean the dirt away. Replace the ring.

## Chapter 7 Maintenance

1. Daily maintenance
  - 1.1 Items in daily maintenance
    - a. Check the element of air cleaner, clear away foreign substance to keep the element clean;
    - b. Check fastening bolts without any loose;
    - c. Check if lubricating oil level is within specified range.
  - 1.2 The element of air cleaner must be cleaned after running time reaches 25h.
  - 1.3 Clear off carbon deposit in ignition plug every 50 operating hours. Check plug clearance and adjust it to 0.6mm~0.8mm if necessary. See Figure 12.



(1) Remove ignition plug (2) Clear off carbon deposit (3) Adjust clearance.

Figure 12

- 1.4 Check radiating fins and clear away the dirt between them if necessary.
- 1.5 Replace lubricating oil: Unscrew bleeding bolt, incline the engine slightly to allow lubricating oil to drain off slowly. Then, tighten the bleeding bolt. Fill clean lubricating oil into engine through lubricating oil filler to specified level.
- 1.6 Check if lubricating oil level is within the specified range after 10 consecutive operating hours.

- 1.7 Clean fuel tank and fuel filter after every 100 operating hours. Open fuel tank cap to take out the filter. Scrub it slightly with brush. Remove fuel tank to clean the interior of tank by eliminating the dirt and water adhering to the interior of tank. Remount the fuel tank, and then properly place the filter at the filler. Add fresh fuel until the level reaches the red mark.
- 1.8 Check fuel pipe for aging at intervals of two years. If aging, hardening, or cracking occurs to the pipe exposes, it must be replaced. After that, tighten the connector to check if it leaks.

## 2. Maintenance before long-term standstill

If the engine will be out of service for a long term for some reason, it shall undergo maintenance before standstill.

- 2.1 Take out the fuel tank to flow the fuel out. Eliminate dirt and water in the tank to make the interior clean. Turn on fuel switch, and unscrew the bleeding plug on the bottom of carburetor to drain out fuel in the carburetor. Then, remount the bleeding plug.
- 2.2 Unscrew the bleeding bolt at the bottom of crankcase to drain out lubricating oil in the crankcase. Then, tighten the bleeding bolt.
- 2.3 Wipe off oil stains and dust on the external surface of gasoline engine with clean cotton yarn, and eliminate the dirt between radiating fins until the engine is clean. Keep it in a clean, dry and well-ventilated place.
- 2.4 Rotate the crankshaft to set the piston at TDC position to prevent air from entering cylinder.  
  
Disposal of spent oil: Please store the spent oil in a special container before sending it to spent oil disposal station. Never pour it randomly.

## **Chapter 8      Transportation and Storage**

The engine shall be handled with care. Inversion and tilt is forbidden absolutely. Protect it from being knocked and damped during transportation. It shall be kept in a clean, ventilated and dampproof place.

If the engine will be out of service for a long time:

- (1) Keep it in a clean, ventilated and dampproof place;
- (2) Drain out lubricating oil in the engine (including the lubricating oil in oil-bath air cleaner);
- (3) Gasoline engine oil seal shall be valid for not less than 6 months under normal packing, transportation and storage conditions.

## **Chapter 9      Unpacking**

Precautions for unpacking:

- Keep the gasoline engine upright and unpack it with care!
- After unpacking, check if Packing List, Certificate of Conformity, Warranty Card and User's Manual are present. Verify if these items on packing list are in conformity with the physical goods.
- The gasoline engine provided by our company is of good quality, environmental protection and high performance-to-price ratio. If you have any trouble or any question, please contact local dealer or directly call after sales service hotline of our company.



## Chapter 10    Warranty Description

To every user:

Thank you for your choice of this series of general gasoline engine. According to the Regulations for Responsibilities about Repair, Replacement and Return of Agricultural Mechanical Products and sincere promise to user, the following services will be available for you with the Warranty Card and Invoice.

1.        Warranty period of complete engine is half a year and that of main parts and components is one year from the date when the gasoline engine is purchased.
2.        The following circumstances are out of range of warranty:
  - a.        Early wear and fault due to improper operation and maintenance.
  - b.        Fault due to your own refitting, adjustment and removal which is not allowed in the User's Manual.
  - c.        No Warranty Card or valid Invoice and failure to prove the product purchased is within the valid period of warranty.
  - d.        Product specifications or model in the Warranty Card or Invoice unconfirmable with the product to be repaired, or being altered.
  - e.        Original appearance of damage not retained after fault occurs, or unable to make technical appraisal on fault causes due to unauthorized treatment without consent of dealer or repairman.
  - f.        Fault due to operators that do not obtain any training qualifications issued by relevant authorities.

## Chapter 11 Installation Dimension

Installation dimension (See Figure 13)

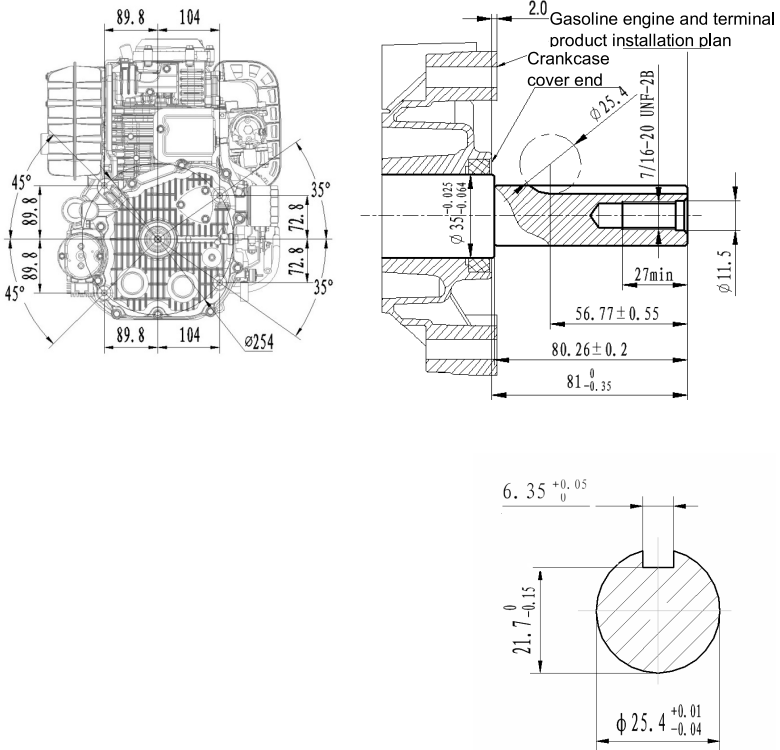

Figure 13





**CHONGQING ZONGSHEN GENERAL POWER MACHINE.,LTD.**

Address:Zongshen industry Zone,Banan District,Chongqing 400054,China

Phone:0086-23-66372525      Hot Line:0086-4001696444

<http://www.zongshenpower.com>

729#/V1.5